



# TRAILBLAZER



SERVING THE SOUTHERN CALIFORNIA ADVANCED/CHALLENGE SQUARE DANCE COMMUNITY

Apr/May, 2007

Volume XXVI Number 2

## THE PRESIDENT'S MESSAGE

BY  
John & Carolyn Melstrom



JOHN &  
CAROLYN  
MELSTROM

It was very gratifying to see the turnout of dancers at our February weekend with Bill Haynes. Although the Superbowl was scheduled for our weekend, we still had a great turnout of loyal dancers. Bill, "the gentle giant", kept everyone "smiling" with his challenging calling. One call remains quite vivid in my mind. At the C3A dance, Bill called Split Catch, Left Catch 2, 2. At first I thought it was some sort of wardrobe malfunction at the ballet. Fortunately, Bill called it again more slowly and I realized it had been a brain malfunction at a square dance.

Fortunately, Bill called it again more slowly and I realized it had been a brain malfunction at a square dance.

In past Newsletter issues we have occasionally published some of the more memorable remarks made by the callers. At Bill's dance I told everyone to remember some of these "pearls of wisdom". I found it very difficult to remember any. I would hear one, try to keep it fresh in my memory, and then proceed to forget it as soon as the next call occurred. I certainly validated the term "short-term memory". It also pointed out how focused we get while following a caller's instructions. We did come up with several of Bills quotable quotes and they are listed elsewhere in this newsletter. We'll try to keep these quotes continuing on a regular basis, so everybody keep your ears tuned at the dances.

March's dance with Sandie Bryant was a big success. With no Superbowl to contend with, dancers turned out in force. Sandie's smooth styling and beautiful voice kept everyone entertained. We even got some of  
(Continued on page 3)

## NOTICE

**Location change  
for the Saturday April 7 dance  
with Vic Ceder.**

**We will be dancing at MEL's in  
Westminster  
Saturday and Sunday**

## NOTICE

### Coming Trailblazer Dances

Friday C-3A—Saturday A-2  
Sunday—1st Session C-1, 2nd Session C-2  
*See the last Page for Locations*

#### 2007

Apr 6, 7, 8	Vic Ceder
May 4, 5, 6	Mike Jacobs
June 1, 2, 3	Lee Kopman
Jul 6, 7, 8	Sue Curtis
Aug 3, 4, 5	Darryl Lipscomb
Aug 31, Sept 1, 2	Anne Uebelacker
Oct 5, 6, 7	Barry Clasper

**SPECIAL EVENTS!!**

April 13-15, 2007	<b>48th CALIFORNIA Square Dance Convention</b> Raincross Square Convention Center, Riverside, CA MS thru C
May 25-27, 2007	<b>MEMORIAL DAY WEEKEND</b> Hemet, CA A-2 & C-1 Featuring: Romney Tannehill, Bronc Wise, Johnny Preston

2006 - 2007  
**TRAILBLAZER BOARD MEMBERS**



President	John & Carolyn Melstrom
1st Vice President	John & Barbara Marshall
2nd Vice President	Connie Thousand & Roger Byelick
3rd Vice President	Vacant
Secretary	John & Peggy Martin
Treasurer	Robert & Vickie Morris
A Square D Rep	Jeff Overbey
President Emeritus	Craig Shucker



Become the next TB Newsletter Editor and then YOU can put your picture in the newsletter. [As long as someone else is willing to take it.]

**For more EVENTS check out our new website**  
**[Http://www.trailblazers-socal.org](http://www.trailblazers-socal.org)**



STATEMENT OF POLICY

**TRAILBLAZER** is published by Trailblazers Square Dance Club for the purpose of providing a means for dissemination square dance information to the Advanced and Challenge Community. The Editor and Publisher reserve the right to exercise their discretion in the acceptance, rejection or editing of any proffered information, listings or advertising based upon their determination of the best interest of square dancing. The opinions which may be expressed herein do not necessarily reflect the opinions of the Editor, Publisher or Trailblazers. Your views are encouraged. Any article herein may be reprinted with credits to **TRAILBLAZER** and the author.

PUBLISHING DATA

**TRAILBLAZER** is published six times a year: February, April, June, August, October and December.

MAILING ADDRESS

Address all correspondence to **TRAILBLAZER**  
441 21st Street, Manhattan Beach, CA 90266

STAFF

Editor/Publisher – Mickey & Steve Klinger (310)802-8190,  
E-mail: klingersrmk@earthlink.net  
Photographers – Open  
Webmaster — Karl Springer,  
E-mail: webmaster@trailblazers-socal.org

DANCE, CLASS & WORKSHOP LISTINGS

No charge for listings. Regular dances will not be listed under special events. Call schedules will not be included in regular dance listings. However, if a schedule of callers is sent, we will include a listing on our website.

ADVERTISING

Full Page (8 x 10) = \$30                      Half Page (8 x 5) = \$20  
Qtr. Page (3.75 x 5) = \$10                      Bus. Card (3 x 2) = \$ 6.50  
Advertising must be camera ready copy, black ink on white paper. Full page originals cannot be reduced to a half-page.

REMITTANCE

Make all checks for advertising or listings payable to **TRAILBLAZER**. Payment must accompany all orders for advertisements and listings.

(Continued from page 1) **[President's Message]**

her more memorable quotes before she even began calling. She also commented that reading the Workshop Highlights from former months helped her prepare for the A2 workshop on Saturday. We proceeded to demonstrate that, despite having been previously introduced to calls at workshops, we certainly benefited from a re-visit to those calls. I think that we demonstrated a lack of "long-term memory".

Some of the calls and concepts from the February and March dances are listed in the Workshop Highlights section in this newsletter. Any mistakes are definitely not of the callers, but of my memory and interpretation.

Nearly four squares of Trailblazers attended Lee and Steve Kopman's Winter Classic in Las Vegas in mid-February. They called a wonderful dance. It seemed almost like one of our regular monthly Trailblazer dances. When Lee and Steve realized that they had scheduled next year's dance opposite our dance, they graciously changed the date so as not to conflict. We very much appreciate their willingness to make the change.

There was one additional event that made the Las Vegas weekend memorable. My car overheard me talking to my neighbor about buying his car the day before I left for Las Vegas. Needless to say, one day into my trip and my car decided to commit suicide. After shipping my car back home and having a diagnostic autopsy, it looks like I will indeed buy my neighbor's car. I have just learned a new way to lose in Las Vegas.

Elections for new Trailblazer officers take place at our April dance. The slate of nominees is as follows:

President – John & Barbara Marshall

1<sup>st</sup> Vice-President – John & Carolyn Melstrom

2<sup>nd</sup> Vice-President – John & Peggy Martin

3<sup>rd</sup> Vice-President – Barbara Shimomura

Secretary – Bruce & Nancy Rosenblum

Treasurer – Robert & Vickie Morris

A Square D Rep – Jeff Overbey

(Continued on page 6)

## NEW TRAILBLAZER MEMBERS



Jane Clewe



Clara Baker



Barbara Mosby

Not pictured:  
Debby Stopp

Hope to have picture for next newsletter.



### Workshop Highlights

Bill Haynes

Here are some of the calls and concepts worked at the A2 Workshop:

The But concept – Example: Chain Reaction,  
But replace the  $\frac{3}{4}$  Cast Off

Any Hand Swing Thru and  $\frac{1}{4}$  Thru (from In-  
verted Lines, Boxes, Magic)

Transfer and ...

All 8 and All 4 Couples

Split Recycle

Spin the Windmill (from Left  $\frac{1}{4}$  Tag or Fac-  
ing Lines)

Reverse Roll Away

Roll Right to a Wave from Parallel Waves

Smile,  
Bill

### Workshop Highlights

Sandie Bryant

Here are some of the calls and concepts worked at the A2 Workshop:

T-Bones – Leaders / Trailers: Split Counter  
Rotate, Peel and Trail, Peel Off, Scoot  
Back, Follow Your Neighbor & Spread.

Split Counter Rotate from Tidal Waves, Paral-  
lel Waves, Diamonds, and T-Bones.

From Right Hand Columns with Boys #1 and  
#2 in the column – Girls Right Roll to  
a Wave and Girls Start Recycle.

T-Bones – identify Partner.

Magic Columns – Those facing Start Pass and  
Roll, Those facing Start Pass the Ocean.

Inverted Lines with Centers Facing In – Cen-  
ters Start Load the Boat.

Right Hand Columns with the #1 person in the  
Column  $\frac{1}{4}$  Right – Motivate.

Take a deep breath, relax, and have fun.  
Sandie



**Bill Haynes**  
**February 2007**



**Sandra Bryant**  
**March 2007**

# DIAGRAMS BY ROOTH

## BILL HAYNES — A2 WORKSHOP MATERIAL

ANY HAND: SWING THRU — from inverted lines



ANY HAND: 1/4 THRU — from a box of four



LEFT SPIN THE WINDMILL — from facing lines

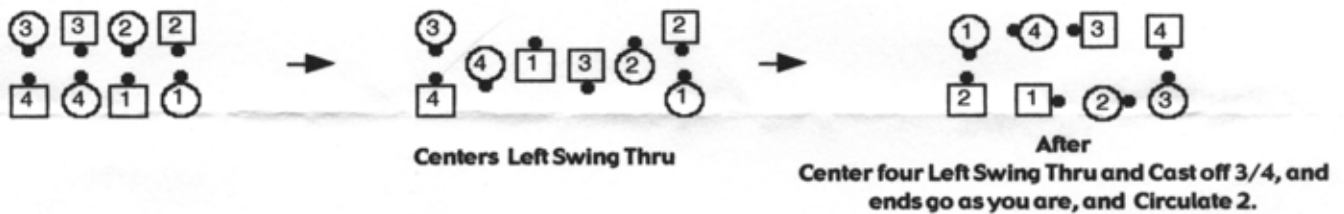

## SAUNDRA BRYANT — A2 WORKSHOP

MOTIVATE — from right-hand column with #1 in column quartered right

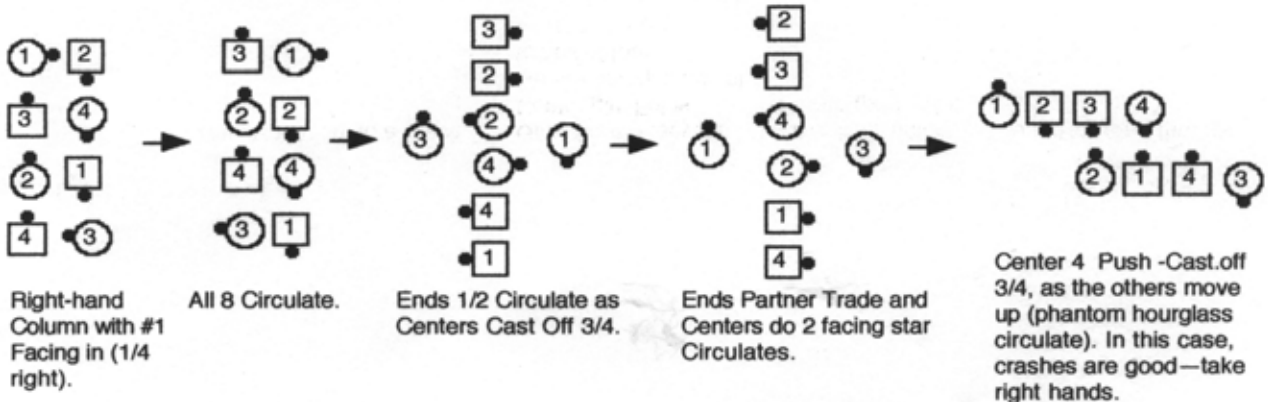

GIRLS ROLL RIGHT to a WAVE and GIRLS START RECYCLE — from right-hand columns with boys as # 1. and #2.

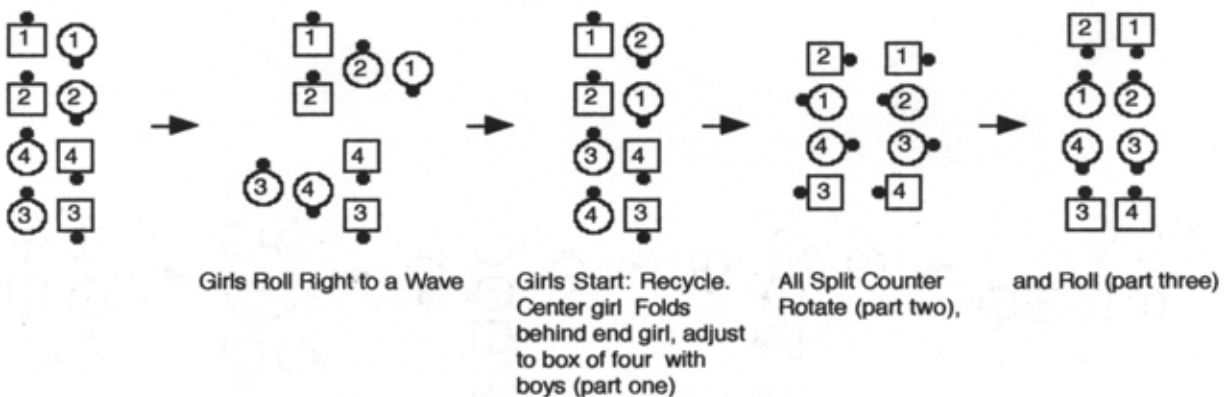

(Continued from page 3) **[President's Message]**

These candidates have committed to serving the club and providing the leadership needed to continue our tradition of excellence. Please give them your support and don't hesitate to volunteer if called upon. Be sure to attend April's dance and cast your important vote.

April features Vic Ceder and May showcases Mike Jacobs, so put these important dates on your calendar.

See you on the dance floor.



**Caller Quotes**

**Bill Haynes**

Smile, your having a good time.  
Think about it tonight with your Sweet 'n Low  
and Sugar Twin.  
Don't worry, you're not on video.  
Nod up and down like you're having a good time.  
See, you're farther than you were before.

**Caller Quotes**

**Sandie Bryant**

If I knew what I did, I'd call it again.  
Cross Chain and Roll and don't face the outside two.  
The OTHER left.  
Is it something I said?  
Brain fart.  
Ah So (at the A2 level)  
I don't do those things often.  
Anytime today!



### A note of Thanks

We wanted to let you know how much we appreciate the help, patience and friendliness extended to us during the Saturday sessions and Sunday C1 session.

We are unable to attend the high level workshops at home in Las Vegas that most of you can attend. We attend some of these whenever we can.

Your graciousness was extended even at Bakersfield. Numerous people had told us to stay out of the C1 hall as all of the squares were set up and we would never dance. This proved to be completely untrue as we danced every tip that we had the energy to dance.

Thank you Trailblazers for being you,  
Suzy & Richard

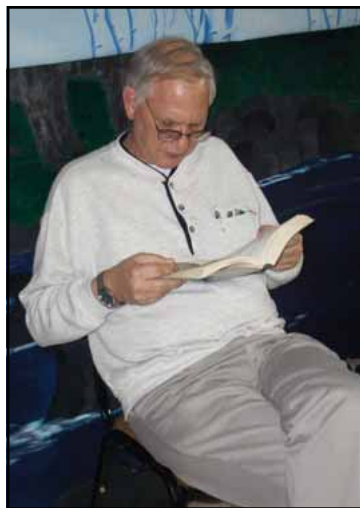

**Tommy says: Check out our new website at  
[Http://www.trailblazers-socal.org](http://www.trailblazers-socal.org)**

\*

**Friday Schedule**  
**C-3A** 8:00 - 11:00 pm  
 C-3 Tips at 10:30

ROSEMEAD BLVD  
 TEMPLE CITY BLVD  
 KAUFFMAN AVE.  
 BALDWIN AVE.  
 LONGDEN AVE  
 WOODRUFF AVE  
 LAS TUNAS DR  
 WOMEN'S CLUB  
 TO 710 FWY ← 10 FWY → TO 605 FWY →

TEMPLE CITY WOMEN'S CLUB  
 9704 Woodruff Ave., Temple City

**Saturday Schedule**  
**A-2** WORKSHOP: 2:15 - 5:00 pm  
 DANCE: 7:30 - 10:00 pm  
 Two C-1 \*Tips each session  
 Two C-2 \*Tips 7:00 - 7:30 pm

COMMUNITY CENTER  
 105 FWY.  
 ROSECRANS AVE.  
 SOMERSET BLVD.  
 ALONDRA BLVD.  
 710 FWY.  
 GARFIELD AVE.  
 PARAMOUNT BLVD.  
 DOWNEY AVE.  
 605 FWY.  
 91 FWY.

PARAMOUNT COMMUNITY CENTER  
 14400 Paramount Blvd., Paramount

**Sunday Schedule**  
**C-1** 11:15 am - 1:45 pm  
 One C-2 \*Tip  
**C-3B** 2:45 - 3:10 pm  
**C-2** 3:15 - 5:30 pm  
 Two C-3A \*Tips

SHOPPING CENTER  
 22 FWY.  
 WESTMINSTER BLVD  
 BOLSA AVE  
 EDINOR AVE  
 405 FWY  
 BOLSA CHICA RD.  
 SPRINGDALE ST.  
 GOLDENWEST ST  
 BEACH BLVD

Located in Shopping Center  
 5946 Westminister Ave., Westminister  
 (at Springdale)

\*

**UNTIL FURTHER NOTICE,  
 ALL FRIDAY NIGHT C-3A  
 DANCES WILL BE HELD AT  
 Temple City Women's Club  
 9704 Woodruff Avenue  
 (626) 286-9930**

# TRAILBLAZER

441 21st Street  
 Manhattan Beach, CA 90266

ADDRESS CORRECTION REQUESTED

FORWARDING AND POSTAGE  
 GUARANTEED

